

MY LEARNING MENU

WEEK OF: MAY 25 - 29

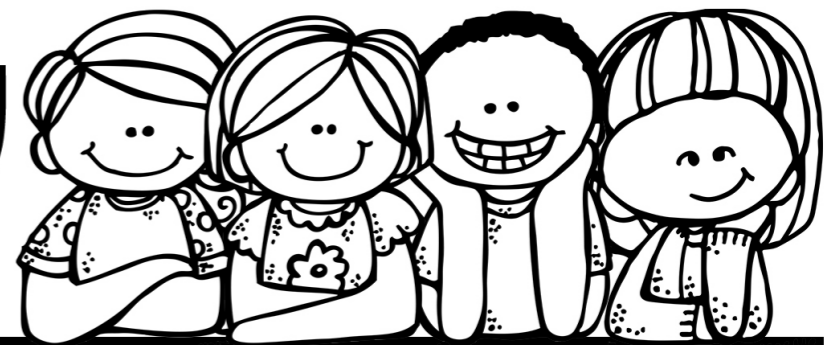

	MONDAY	TUESDAY	WEDNESDAY	THURSDAY	FRIDAY
READING	<p style="text-align: center;">↓</p> <p style="text-align: center;">No School Memorial Day</p>	<p>Read a fiction or nonfiction book of your choice for at least 20 minutes.</p> <p>Complete <u>one</u> of the reading responses provided.</p>	<p>Log onto Epic. Read the assigned book "Our Natural Resources" found in your mailbox. Then, take the quiz at the end.</p>	<p>Read a fiction or nonfiction book of your choice for at least 20 minutes.</p> <p>Complete <u>one</u> of the reading responses provided.</p>	<p><i>Catch-up Day!</i> Use this time to complete any activities you need. If you're done, do the suggested enrichment activities!</p> <p><i>Flashlight Friday!</i> Enjoy a book of your choice for 20 minutes in a dark, cozy spot with a flashlight 😊</p>
WRITING	<p style="text-align: center;">↓</p>	<p><i>Daily Journal Entry:</i></p> <ul style="list-style-type: none"> How did you celebrate Memorial Day? <p><i>Paragraph of the Week:</i></p> <p>○ Tuesday task Write a paragraph giving your opinion about where you would rather live: near a volcano or a place with earthquakes.</p>	<p><i>Daily Journal Entry:</i></p> <ul style="list-style-type: none"> How do you feel about distance learning? <p><i>Paragraph of the Week:</i></p> <p>○ Wednesday task</p>	<p><i>Daily Journal Entry:</i></p> <ul style="list-style-type: none"> What was an act of kindness you noticed this week? <p><i>Paragraph of the Week:</i></p> <p>○ Thursday task</p>	<p><i>Daily Journal Entry:</i></p> <ul style="list-style-type: none"> What are you looking forward to most in June? <p><i>Paragraph of the Week:</i></p> <p>○ Friday task Share your paragraph of Flipgrid, if you want!</p>

MY LEARNING MENU

WEEK OF: MAY 25 - 29

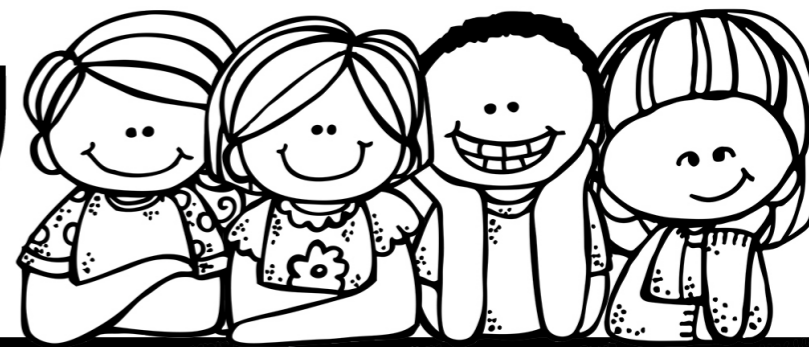

		MONDAY	TUESDAY	WEDNESDAY	THURSDAY	FRIDAY
MATH SPECIALS SOCIAL STUDIES/SCIENCE			<p>Watch the BrainPop, Jr. video "Dollars & Cents." Take the easy quiz to check your knowledge. Then, complete the Coin Match-Up sheet.</p> <p><i>Optional:</i> 2 rounds of math facts</p>	<p>Watch the BrainPop, Jr. video "Counting Coins." Then, complete the Grab and Graph Activity.</p> <p><i>Optional:</i> 2 rounds of math facts</p>	<p>Practice counting coins by completing the Money deck assigned to you on Boom Cards.</p> <p><i>Optional:</i> 2 rounds of math facts</p>	<p><i>Enrichment Options:</i> Watch the Mystery Doug video "How is money made?" Then, click on "Extensions" below the video and do the Bonus Activity - create your own money!</p>
			P.E.	LIBRARY	ART	HEALTH
		<p>Social Studies: It's time to research the country you chose to study back in March! Using the packet found in your black bag you picked up at RMS, complete the "Quick Facts" page about your country. Use NatGeo Kids for information!</p>	<p>Social Studies: In your Country Research packet, complete the "Country Map" and "Country Flag" pages.</p>	<p>Social Studies: In your Country Research packet, complete the "Land and Climate" page and one other page of your choice! It can be any of the remaining pages. If you'd like, you may do more than one extra page!</p>	<p><i>Enrichment Options:</i> Share 3 interesting facts about your country and a reason why someone should travel there on Flipgrid! Also, you may complete a Mystery Science activity that answers "Why is there sand at the beach?"</p>	

MY LEARNING MENU

ADDITIONAL DAILY OPTIONS

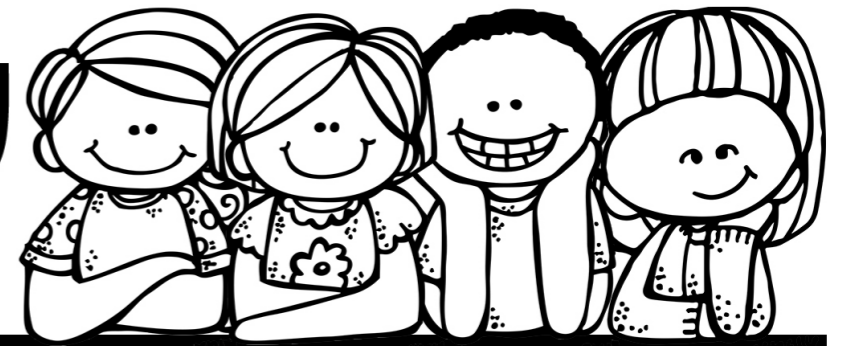

Don't forget to check specialists' websites for daily activities!

Our specialist schedule is as follows:

Monday - **Music** Tuesday - **P.E.** Wednesday - **Library** Thursday - **Art** Friday - **Health**

ELA:

Freckle ELA games & activities

Epic books

RAZ Kids

Storyline Online

PebbleGo

WriteAbout (digital journaling)

Science/Social Studies:

BrainPop, Jr.

PebbleGo

National Geographic Kids

Cincinnati Zoo's daily at-home safari

Mystery Science activities

Compass Rose Twister!

Math:

Brain Busters (click the button on our page for new puzzles)

Freckle daily math facts & games

Prodigy Game

Beat a Partner Game (roll a die and fill in the addition sentence)

Pica, Ferme, Nada

Trash

War Card Game to practice skills (add up 2 or more cards, create 3-digit numbers and compare, select certain place values, etc!)

Memory with clock/time cards

Zoom Meetings

Week of May 25 - May 29

Monday	Tuesday	Wednesday	Thursday	Friday
	<p>10:00 - 10:40</p> <p>Class Meeting: Tally It Tuesday!</p> <p>ID: 620 984 998</p> <p>PW: 2mare</p>	<p>10:00 - 10:40</p> <p>Class Meeting: Writing Wednesday!</p> <p>ID: 620 984 998</p> <p>PW: 2mare</p>	<p>10:00 - 10:40</p> <p>Class Meeting: Think About It Thursday!</p> <p>ID: 620 984 998</p> <p>PW: 2mare</p>	<p>8:15 - 8:45</p> <p>SHAPE Preview with Mr. Woodward</p> <p>ID: 961 8153 9121</p> <p>PW: 1q8Rdm</p>
	<p>12:35 - 1:00</p> <p>Lunch Group with Mrs. Cruz, Mrs. Pacheco & Mrs. Ryan</p> <p>ID: 974 5677 1508</p> <p>PW: Lunch</p>		<p>11:00 - 11:30</p> <p>Gr. 2 & 3 Book Talk with Mrs. Sollauer</p> <p>ID: 987 7615 7112</p> <p>PW: 2Xb9vy</p>	<p>10:00 - 10:40</p> <p>Class Meeting: Fun Friday!</p> <p>ID: 620 984 998</p> <p>PW: 2mare</p>
			<p>12:00 - 12:45</p> <p>Gr. 2 & 3 Artist Café with Mrs. Smith</p> <p>ID: 847 5506 4386</p> <p>PW: 3J5TVi</p>	

READING RESPONSE CHOICES

Choose a task to complete when reading an independent book. There are more choices than school days - pick the 2 you want to do! 😊

NONFICTION #1

Title _____

Author _____

Minutes read _____

The main idea of this book is _____.

Detail #1:

Detail #2:

Detail #3:

NONFICTION #2

Title _____

Author _____

Minutes read _____

3

3 things you discovered: _____

2

2 things you found interesting: _____

1

1 question you still have: _____

FICTION #1

Title _____

Author _____

Minutes read _____

Locate **one sentence** from your reading today that is an **opinion**.

Write the sentence here:

Do you agree with that opinion?

yes

no

FICTION #2

Title _____

Author _____

Minutes read _____

Circle the **genre** of your book:

realistic fiction

mystery

fable

poetry

tall tale

historical fiction

fantasy

science fiction

fairy tale

What are some **features** of this genre? _____

FICTION #3

Title _____

Author _____

Minutes read _____

Complete the following sentences to make a **prediction**.

I **wonder** what will happen to _____ when I read tomorrow.

I **think** that _____.

PARAGRAPH OF THE WEEK

MAY 25 - 29

THIS WEEK'S TOPIC:

You have read a lot of information about different kinds of fast changes to land. With that information in mind, would you rather live next to a volcano or in a place that has earthquakes? Remember to include **three** reasons to support your opinion!

USE THE BELOW CHART TO HELP WITH FRIDAY'S TASK

ARMS

A

Add a word

R

Remove a word

M

Move a word to a better spot

S

Substitute a synonym

CUPS

C

Capital letters

first word of every sentence, proper nouns, and I

U

Usage

make sure all nouns and verbs match (example: she goes NOT she go)

P

Punctuation

every sentence ends with a punctuation mark and commas are used when needed

S

Spelling

all sight words are spelled correctly and you've looked up the correct spelling of words you are unsure about

PARAGRAPH OF THE WEEK

Monday

NO SCHOOL - MEMORIAL DAY

Tuesday

BRAINSTORM

Write all the words and phrases (details!) you know about this week's topic. Include every detail you can think of. Let your mind go, and try to write at least 10 things on your brainstorm.

Wednesday

DETAILS

Choose the 3 most important details from your brainstorm. Write a sentence for each detail. Put the most important detail first, and include an explanation sentence for that detail.

Thursday

TOPIC & CONCLUSION

Write a topic sentence at the beginning of your paragraph that tells the main idea. Then, write a conclusion sentence at the end of your paragraph to wrap up everything.

Friday

REVISE & EDIT & PUBLISH - Oh, my!

Use ARMS to revise your paragraph and make it *sound* better. Then, use CUPS to edit your paragraph and make it *look* better. Check the ARMS and CUPS reference sheet for help! Write your final draft including revisions and edits. If you want, record yourself reading your final paragraph on the Paragraph of the Week Flipgrid. 😊

BRAINSTORM

Tuesday

TOPIC sentence:

Thursday

1st Detail & explanation:

Wednesday

2nd Detail:

3rd Detail:

Thursday

CONCLUSION sentence:

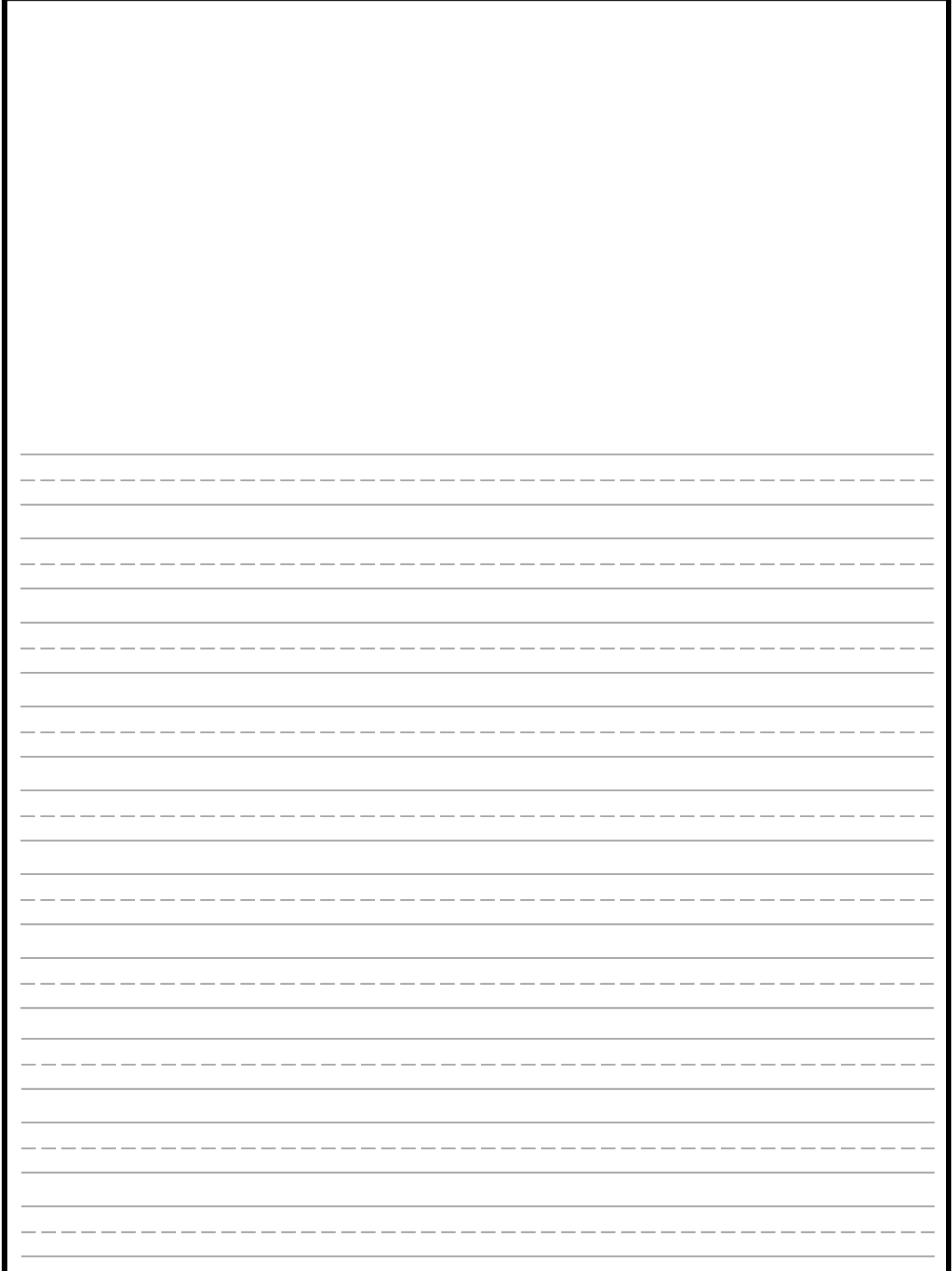

Name: _____









Coin Match-Up

Glue the coin characteristics that go together on the same row.

Name of Coin	Front of Coin	Back of Coin	Amount with \$	Amount with ¢

Coin Match-Up





Cut out the squares below:

\$0.25	1¢	nickel		
quarter	5¢		dime	
	penny	10¢		\$0.01
25¢	\$0.05			\$0.10





GRAB & GRAPH

Name: _____

1 2 3 4 5 6 7 8 9 10

 penny										
 nickel										
 dime										
 quarter										

Grab a handful of coins and tally.

 penny	
 nickel	
 dime	
 quarter	

CHALLENGE!

Count each set of coins. Determine the TOTAL value for each set.



What is the TOTAL VALUE of all the coins COMBINED? _____

Draw the river rocks

Name: _____

Draw rocks breaking up in the river,
starting at the top of the mountain
and ending at the ocean.

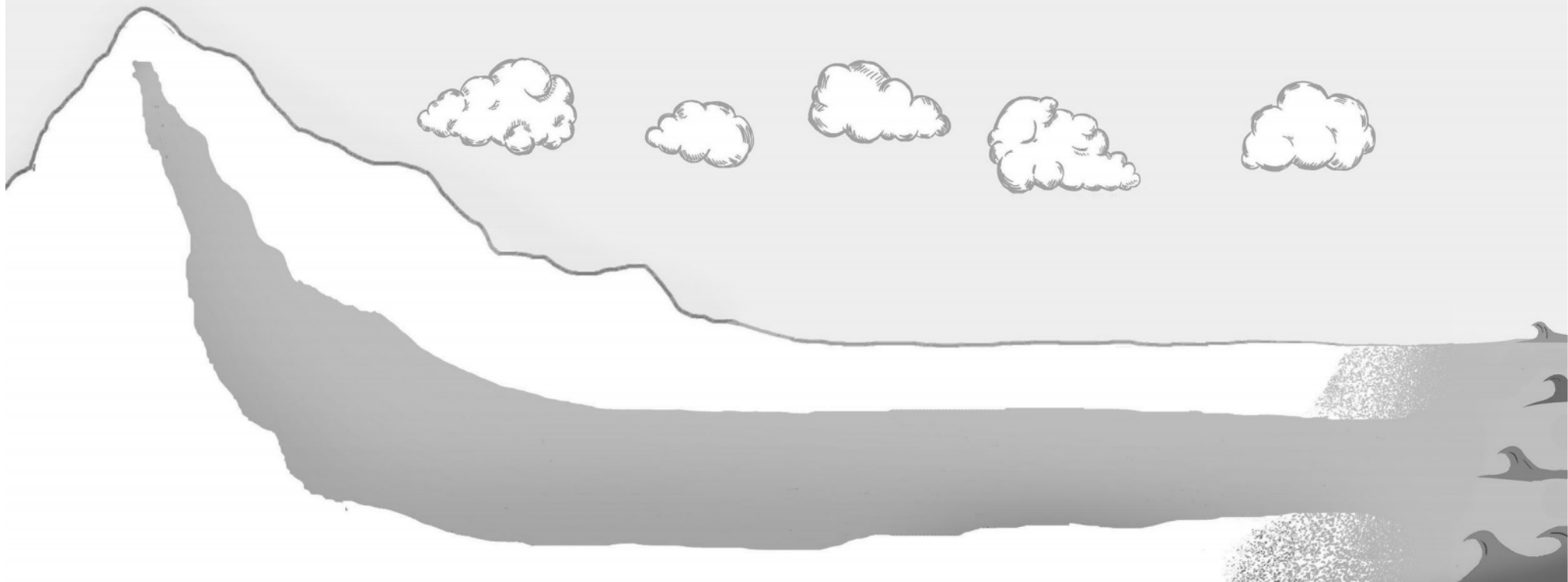

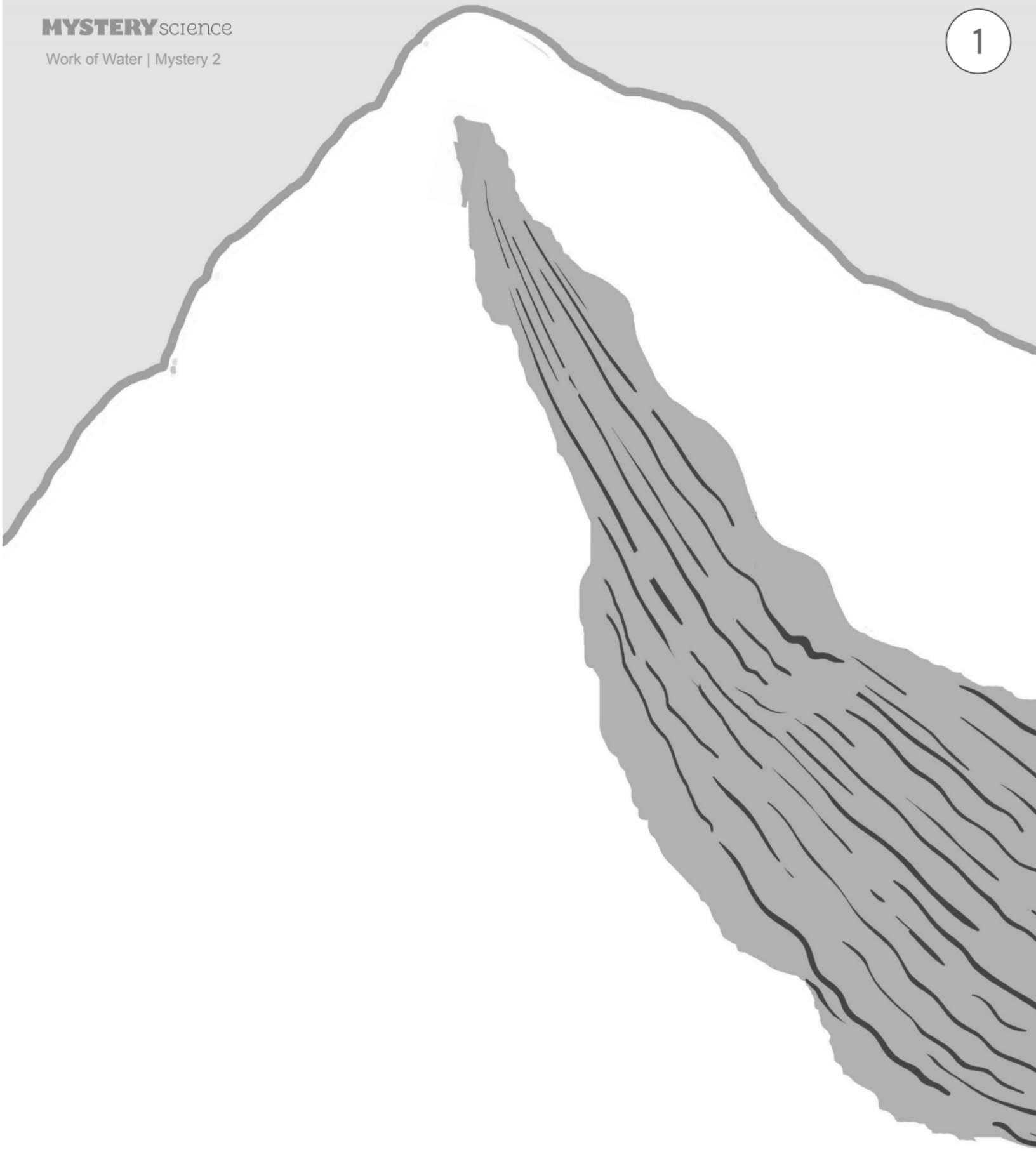

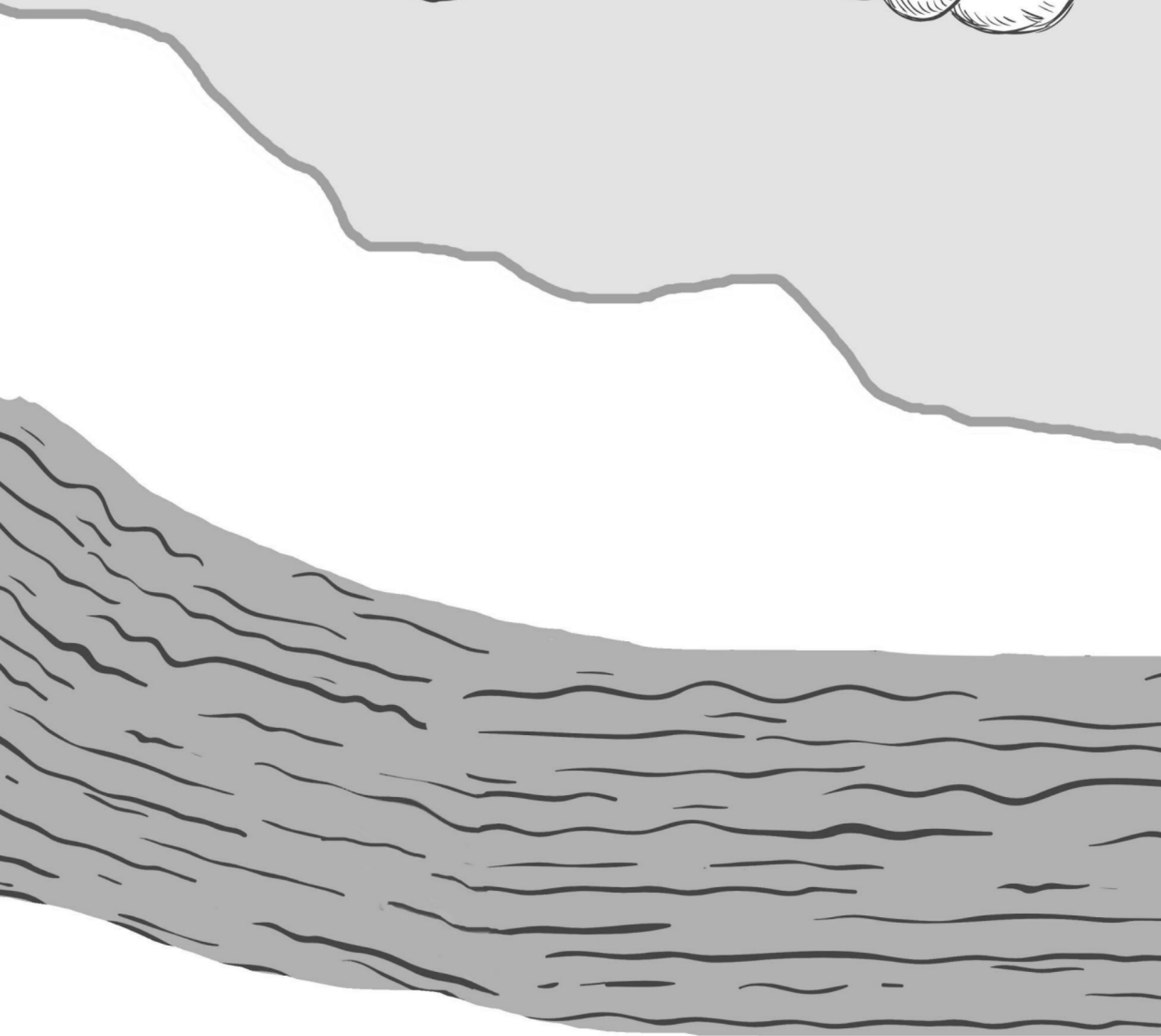

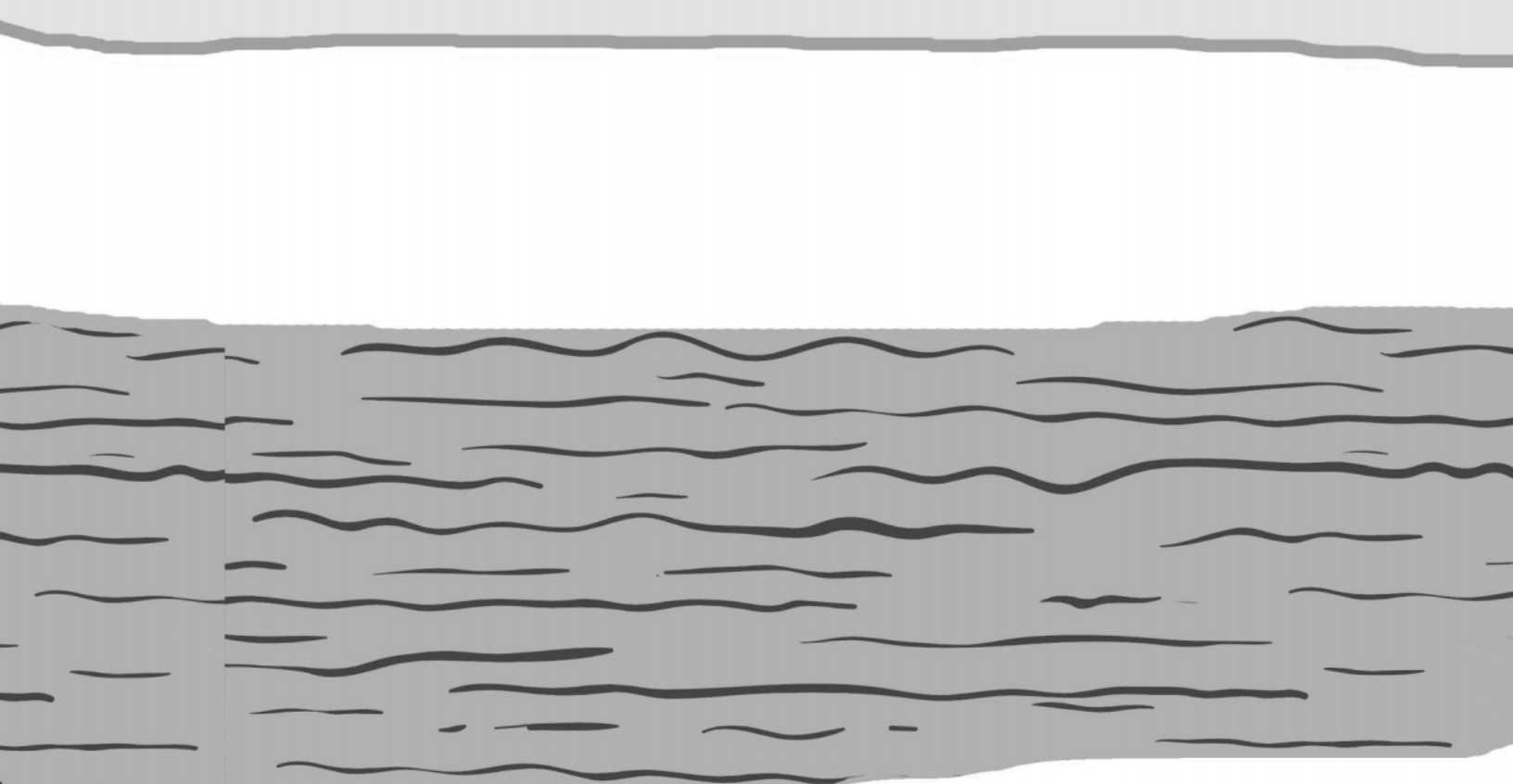

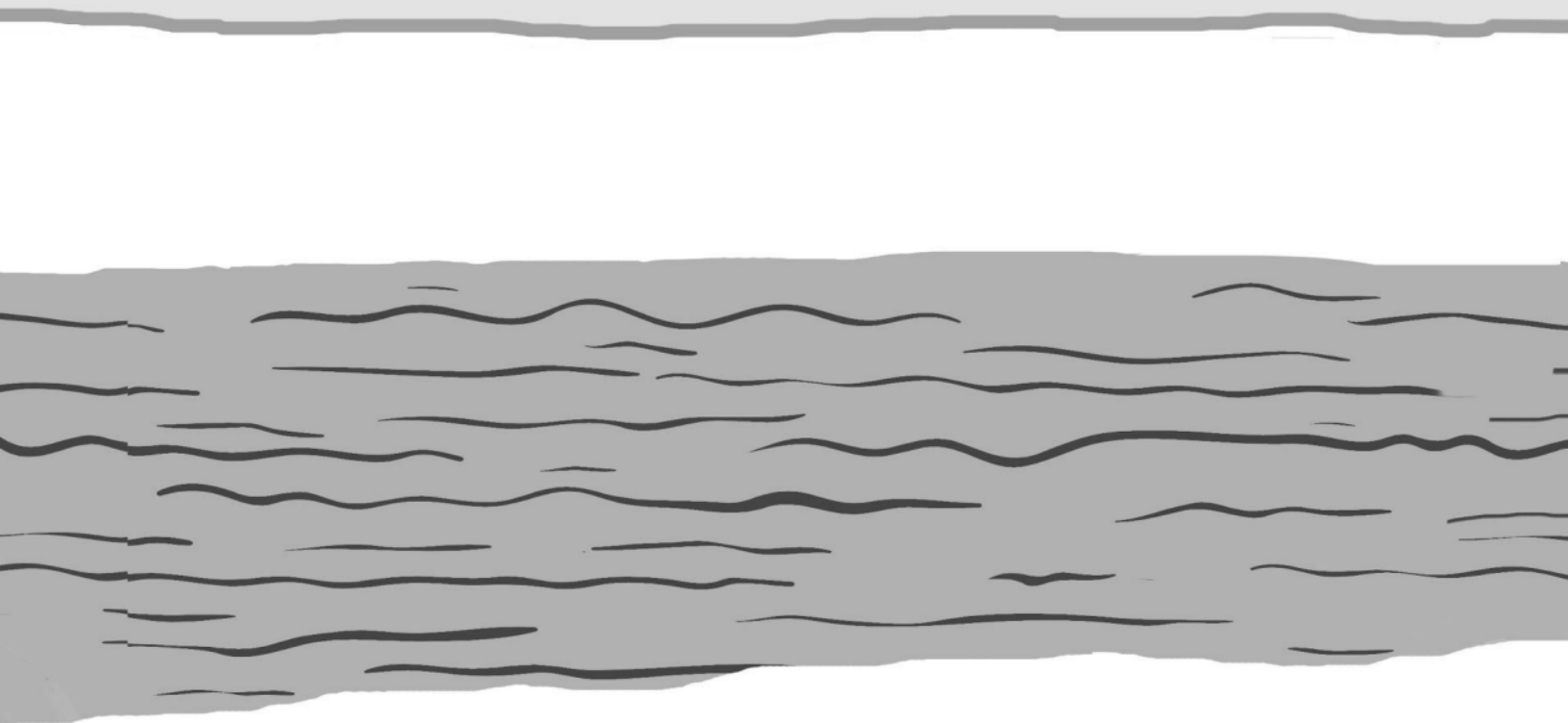

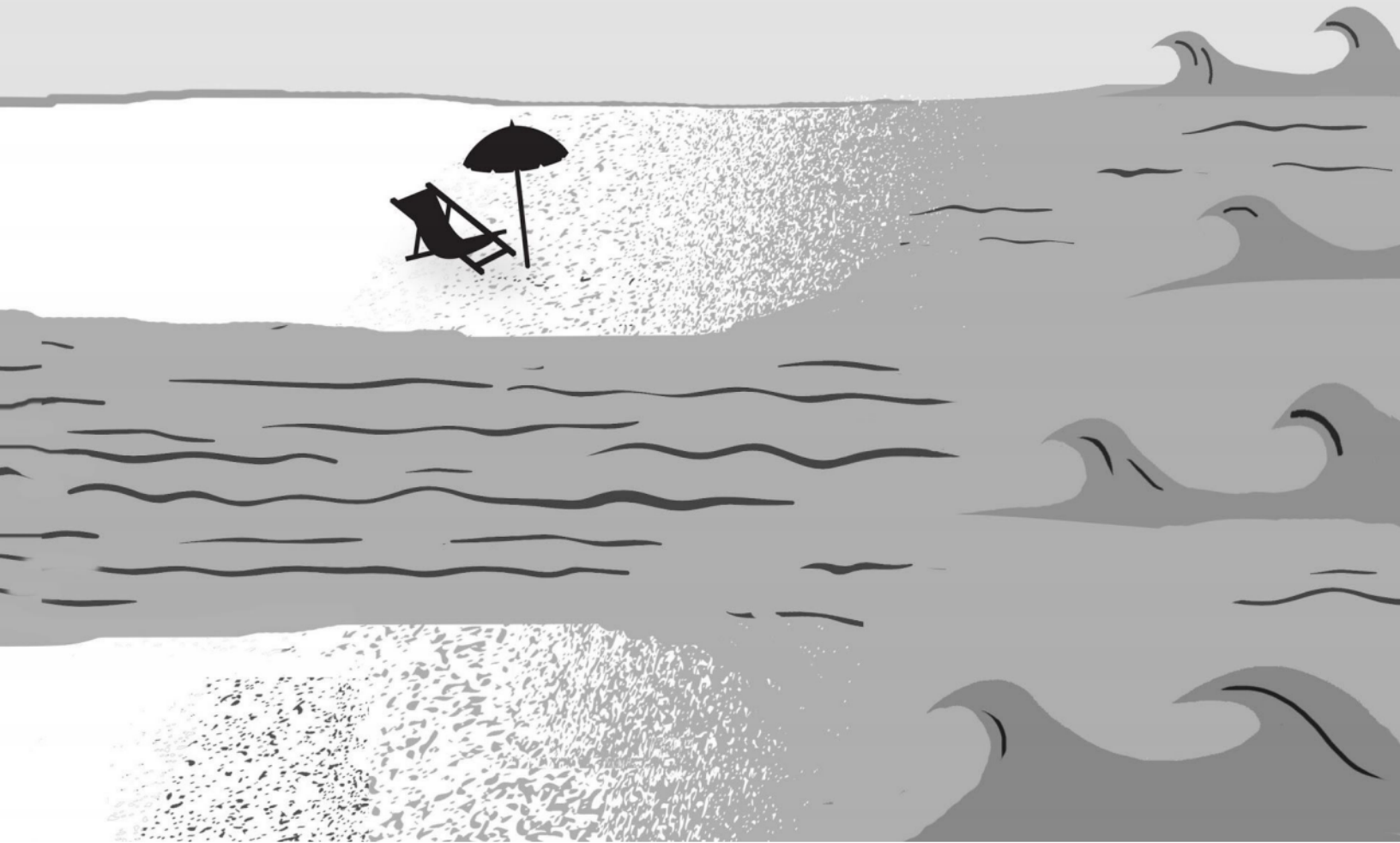

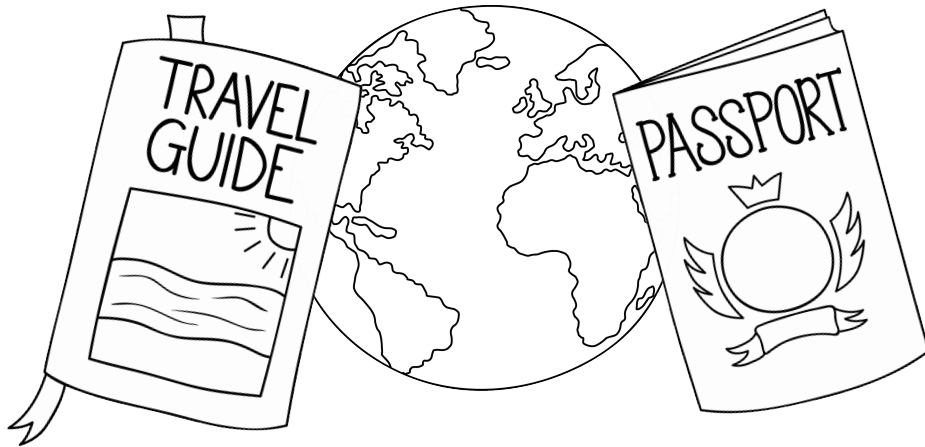

Country Research Flip Book

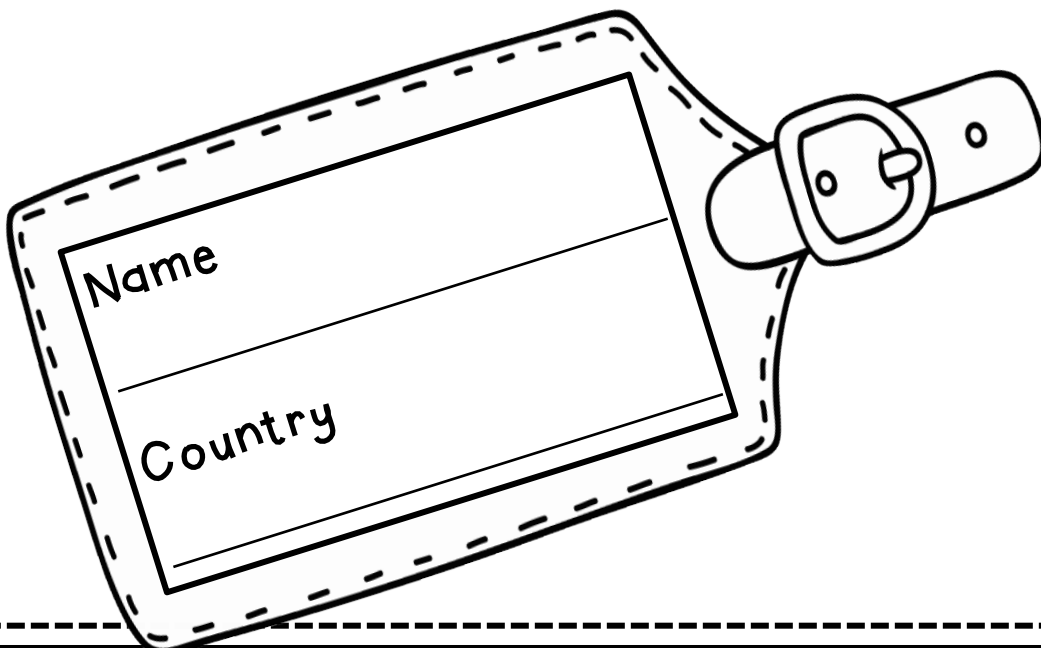

Quick Facts

Country: _____

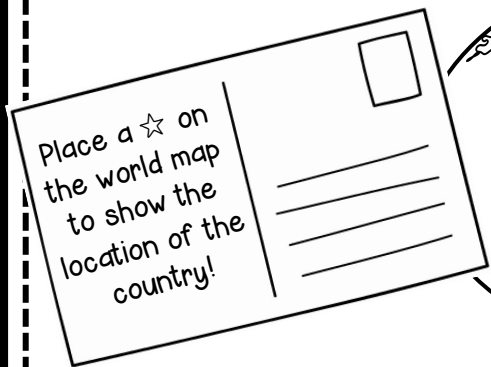
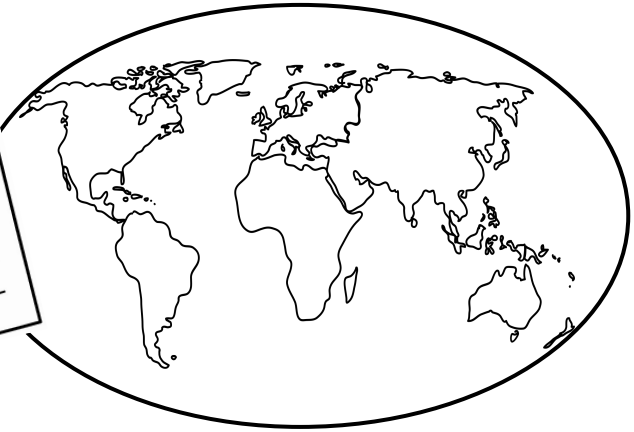

Capital City: _____

Continent: _____

Neighboring Countries: _____

Hemisphere: _____

Population: _____

Language/s: _____

Religion/s: _____

Type of Government: _____

Leader: _____

Currency: _____

Known for Producing: _____

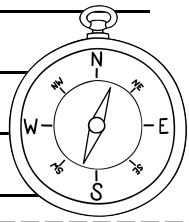

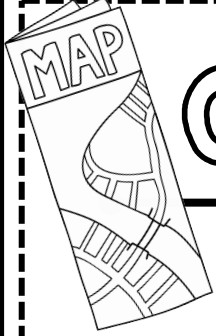

Country Map

Draw a map of the country in the box below. Add your own details to the key at the bottom of the page.

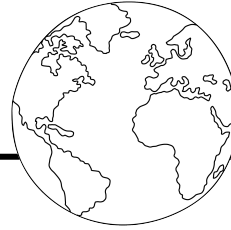

Map

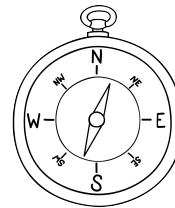

KEY

- ☆ Capital City
- City
- ⚓ Port

Country Flag

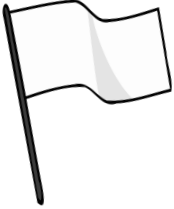

Draw the country flag in the space below. Then, research the meaning of each color/design on the flag and record your information!



Flag

Colors on the flag: _____

What do these colors mean? _____

Are there symbols in the flag design that have important meaning?

Land and Climate



Draw or paste a picture/s of the country's landscape!

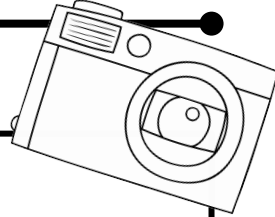

© Katie Walker 2016

Describe the main ecosystem/s in this country:

Maximum Temperature: _____

Minimum Temperature: _____

Rainfall per year: _____

Month with most rainfall: _____

Month with least rainfall: _____

Other information: _____



Land and
Climate



Wildlife



Draw some of the wildlife found in this country in each of the polaroid pictures!

What animals are native to this country?

What other animals can be found here?

Are there any dangerous animals found in this country?

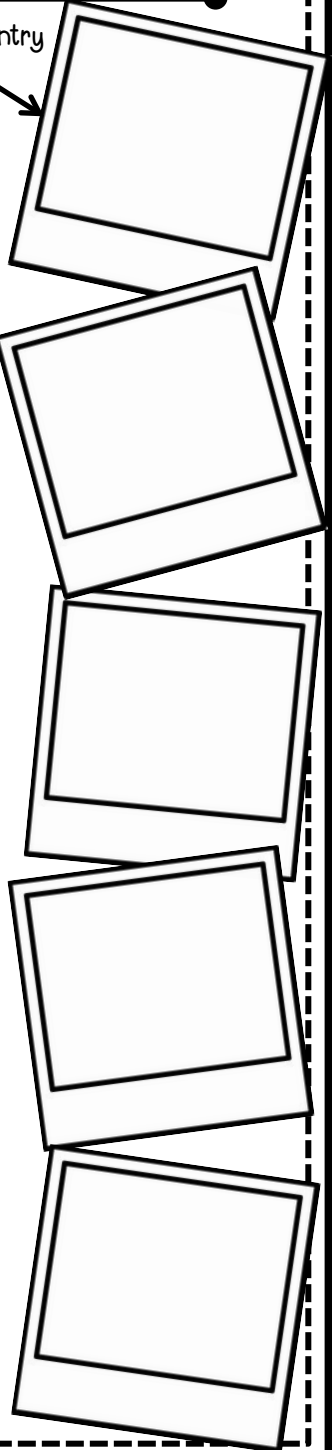



Use the mind map below to record details about the celebrations and traditions of this country.

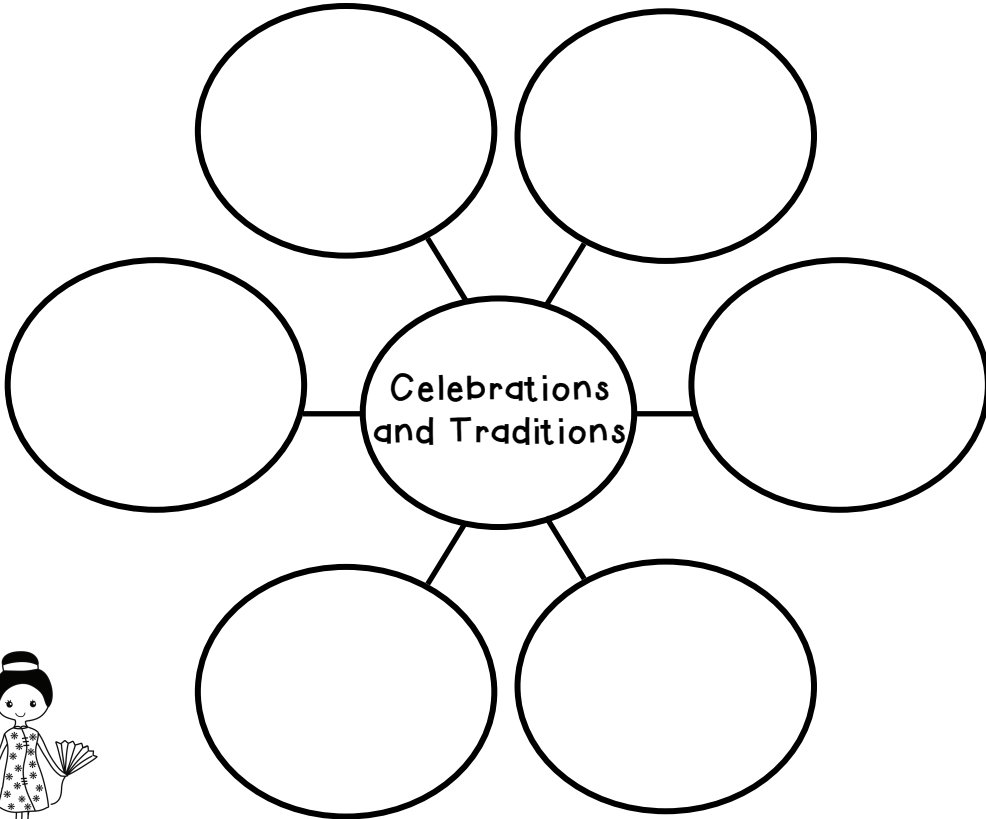

Traditional Dress:

Traditional Food:

Landmarks and Attractions

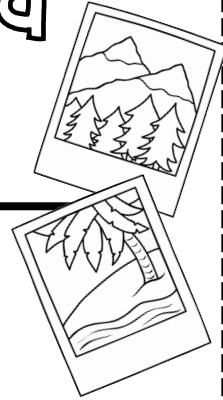

What are the important landmarks and attractions in this country? Record the must-see places to visit in your country below!

Landmarks and Attractions

Name: _____

Why this a great place to visit:

Name: _____

Why this a great place to visit:

Name: _____

Why this a great place to visit:

Name: _____

Why this a great place to visit:



History

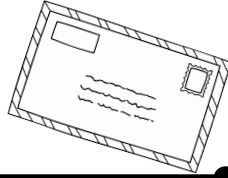

Use the timeline below to record important historical events that have happened in this country.

Date: _____
Event: _____
Description: _____

Date: _____
Event: _____
Description: _____

Date: _____
Event: _____
Description: _____

Date: _____
Event: _____
Description: _____

Date: _____
Event: _____
Description: _____

Date: _____
Event: _____
Description: _____

Date: _____
Event: _____
Description: _____

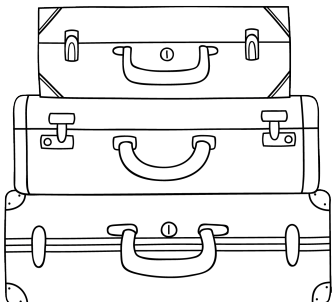

History

